



Turbo

Turbine Flow Meters

Industrial Turbine Meters

Turbo Model

DESCRIPTION

The Badger Meter® Industrial Turbine is a rugged, reliable meter ideally suited for industrial fluid applications. Its compact size and ease of serviceability without removal from the line make this a cost effective selection. Designed with performance in mind, the meter provides a high level of accuracy over a wide flow range with a minimum of pressure loss.

The Turbine meter is available in line sizes of 2 in., 3 in., 4 in. and 6 in.. Its unique straight-through flow profile and ceramic bearing design optimize performance.

To complement the meter, Badger Meter offers a complete line of accessories that includes electromechanical and state-of-the-art electronic transmitters, totalizers, indicators and process controllers.

OPERATION

The Badger Meter Industrial Turbine is a volumetric liquid flow meter that works on the time proven principle of a rotor turning at an angular velocity proportional to the fluid velocity through the turbine. The meter has straightening vanes and a nose cone in the inlet side which minimize upstream turbulence and direct the flow to the rotor effectively. Electronic pickups generate signals from the rotor magnet. The signals are translated to an open collector-transistor pulse output. Mechanical pickups and electromechanical outputs are also available.

APPLICATIONS

The Turbo model is used in a wide range of fluid applications covering from water to oils and solvents to acids. The meter is used in water treatment systems, loading and unloading of tankers or rail cars, batching systems, or simply inventory control of a process fluid. Anywhere high volume and/or high flow rates are at least sometimes required in the application, the Turbo meter is likely the right choice.

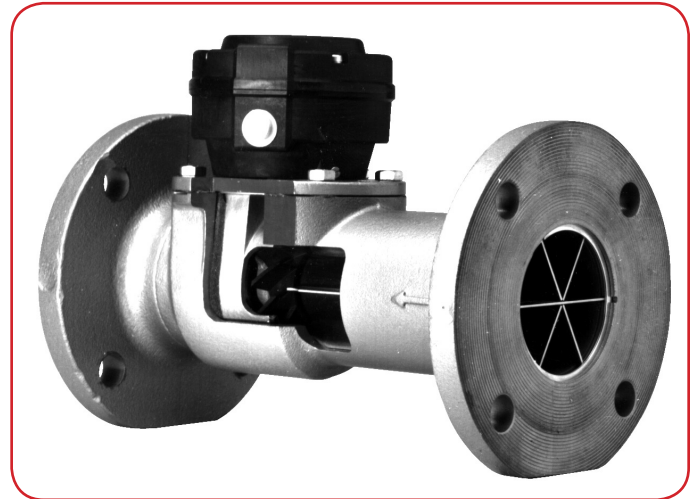

MATERIALS

Housing	Cast iron, bronze or 316 stainless steel
Head	Bronze or stainless steel
Rotor & Nose Cone	Ryton
Bearings	Ceramic
Straightening Vanes	316 Stainless Steel
O-Ring and Tetraseal	Buna N, EPR or Viton
Head Gasket	Nitrile Binder (used with Buna N seals) or Chloroprene Binder (used with EPR and Viton seals)

FEATURES

- Long lasting ceramic bearings
- Simple inline serviceability
- Accuracy of $\pm 0.5\%$ to $\pm 1.5\%$
- Repeatability of 0.25%
- Low pressure loss
- Three housing materials available



Badger Meter

TRB-DS-01191-EN-05 (April 2017)

Product Data Sheet

Jamieson Equipment Company
www.jamiesonequipment.com
toll free 800.875.0280



SPECIFICATIONS

System Size	2 in.	3 in.	4 in.	6 in.
Accuracy ±0.5% @ indicated Flow Range	20...160 gpm (76...606 lpm)	60...350 gpm (227...1325 lpm)	100...1000 gpm (378...3785 lpm)	250...2000 gpm (946...7570 lpm)
Accuracy ±1.5% @ indicated Flow Range	8...200 gpm (30...757 lpm)	10...450 gpm (38...1703 lpm)	25...1250 gpm (95...4732 lpm)	40...2500 gpm (151...9464 lpm)
Repeatability*	0.25%			
Temperature Range	32...250° F (0...121° C)			
Minimum Operating Pressure	7 psi (0.5 bar)			
Maximum Operating Pressure	Standard: 125/150 psi (9/10 bar) Optional: 250/300 psi (17/21 bar)			

* Reading over full range tested with potable water at 60° F (16° C).

Flange Face Configurations: (ANSI Standards)

Flat Faced Flanges: 125 lb (57 kg) cast Iron, 150 lb (68 kg) and 300 lb (136 kg) bronze housings

Raised Face Flanges: 250 lb (113 kg) cast iron, 150 lb (68 kg) stainless steel housings

DIMENSIONS

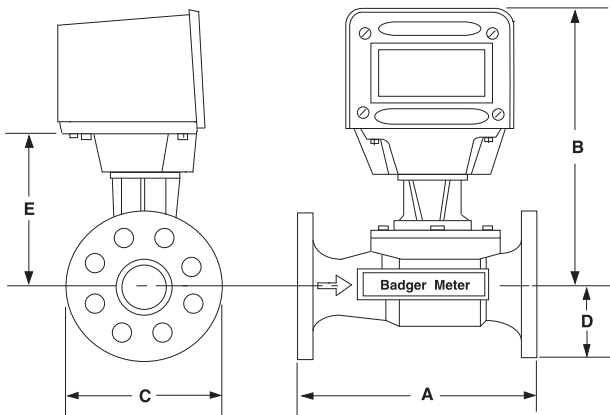

	2 in.	3 in.	4 in.	6 in.
A	10.00 in. (254 mm)	12.00 in. (305 mm)	14.00 in. (356 mm)	18.00 in. (457 mm)
B	13.67 in. (347 mm)	13.67 in. (347 mm)	15.34 in. (390 mm)	16.34 in. (415 mm)
C	6.00 in. (152 mm)	7.50 in. (191 mm)	9.00 in. (229 mm)	11.00 in. (279 mm)
D	2.75 in. (70 mm)	3.50 in. (89 mm)	4.25 in. (108 mm)	5.25 in. (133 mm)
E	6.86 in. (174 mm)	6.86 in. (174 mm)	8.53 in. (217 mm)	10.03 in. (255 mm)
Est. Wt.	30...40 lb (14...18 kg)	40...50 lb (18...23 kg)	60...75 lb (27...34 kg)	100...125 lb (45...57 kg)

PRESSURE LOSS CHART

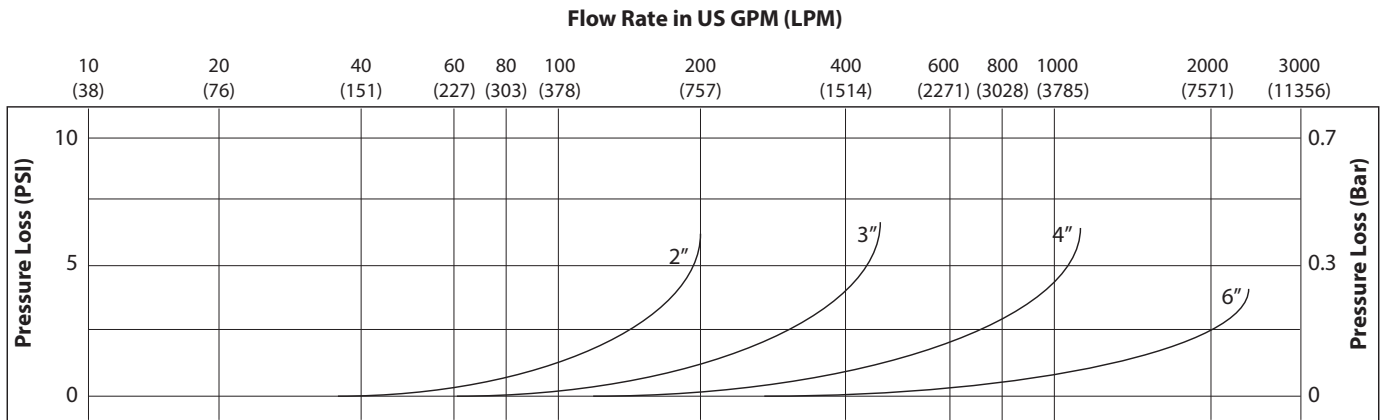

Control. Manage. Optimize.

Trademarks appearing in this document are the property of their respective entities. Due to continuous research, product improvements and enhancements, Badger Meter reserves the right to change product or system specifications without notice, except to the extent an outstanding contractual obligation exists. © 2017 Badger Meter, Inc. All rights reserved.